

WELDED CLEVIS

Spring-Brakes and Service Chambers

OCTOBER
2014

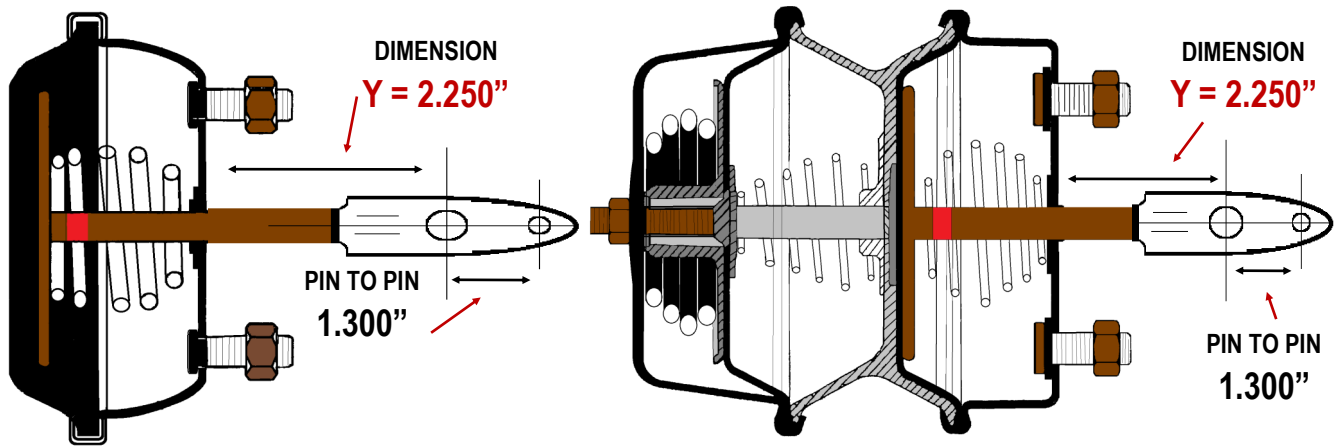

AVAILABLE IN ALL SIZES

Each, PROLINE WC-WELDED CLEVIS style actuator is uniquely designed to be a direct replacement for the ORIGINAL EQUIPMENT WC-WELDED CLEVIS style actuator. When ordering a WC-WELDED CLEVIS style actuator you must know the push-rod distance measured from the NPH / NON PRESSURE HOUSING to the CENTER OF THE LARGE CLEVIS PIN HOLE, as shown in the illustrations above.

MOST MAUFACTURERS REFER TO THIS AS THE “Y” DIMENSION.

In addition to knowing the “Y” dimension, it is absolutely essential to note that all OE, WC-WELDED CLEVIS style actuators are designed with a different clevis than the standard threaded screw-on style clevis we are all accustomed too. The difference is that all WC-WELDED CLEVIS style actuators utilize a clevis with

1.300” PIN TO PIN CENTERLINE SPACING...

IMPORTANT:

**WC-WELDED CLEVIS ACTUATORS MUST HAVE A CLEVIS
WITH 1.300” PIN TO PIN SPACING. NO EXCEPTIONS.**

IF YOU USE A STANDARD-THREADED PIN TO PIN STYLE CLEVIS, IN PLACE OF THE WELDED 1.300” PIN TO PIN STYLE CLEVIS, THE AUTOMATIC SLACK ADJUSTER WILL NOT OPERATE CORRECTLY, NOR MAINTAIN THE REQUIRED “LINING TO DRUM” CLEARANCES NECESSARY TO PROVIDE SAFE BRAKING.

FOR INFORMATION: PLEASE CONTACT

ALEX AT: PROLINE_HD, 108 INDUSTRIAL RD, TN 37012,

PH: (615) **529-2727** FX: (615) 529-1150, Email: **ALEX@PROLINEHD.net**

WELDED CLEVIS

Spring-Brakes and Service Chambers

WELDED CLEVIS SPECIFICATION / APPLICATION / CROSS-REFERENCE							(CAGED) DISTANCE FROM THE SURFACE OF THE NPH TO THE CENTERLINE OF THE LARGE CLEVIS PIN HOLE	"Y"
SIZE	PROLINE_HD PART NO.	CROSS-REF ONLY PART NO.	STROKE	STROKE	PROLINE_HD TYPE	PRODUCT DESCRIPTION		
3030	PLBTS3030WC-2.25	GC3030CW	STD	2.500"	SPRING BRAKE	_fits NAVISTAR, VOLVO, MACK, FREIGHTLINER	2.250"	
3030	PLBTS3030LSWC-2.25	GC3030LCW	LONG	3.000"	SPRING BRAKE	_fits NAVISTAR, FREIGHTLINER	2.250"	
3030	PLBTS3030WCP58-2.87	GC3030S6CW	STD	2.500"	SPRING BRAKE	_fits KENWORTH, PETERBILT, PACCAR- W/5/8" CLEVIS PIN	2.870"	
3030	PLBTS3030LSWCP58-2.87	GC3030LS6CW	LONG	3.000"	SPRING BRAKE	_fits KENWORTH, PETERBILT, PACCAR- W/5/8" CLEVIS PIN	2.870"	
3030	PLBTS3030WC-3.06	3430955	STD	2.500"	SPRING BRAKE	_fits THOMAS BUS	3.063"	
3030	PLBTS3030LSWC-3.06	3230955	LONG	3.000"	SPRING BRAKE	_fits THOMAS BUS	3.063"	
3030	PLBTS3030WC-4.20	3430952	STD	2.500"	SPRING BRAKE	_fits MACK TRK	4.200"	
3030	PLBTS3030LSWC-4.20	3233953	LONG	3.000"	SPRING BRAKE	_fits MACK TRK	4.200"	
3030	PLBTS3030WC-6.80	GC3030S5CW	STD	2.500"	SPRING BRAKE	_fits TRAILER-SPRING SUSPENSION, INTRAAX	6.800"	
3030	PLBTS3030LSWC-6.80	GC3030LS5CW	LONG	3.000"	SPRING BRAKE	_fits TRAILER-SPRING SUSPENSION, INTRAAX	6.800"	
3030	PLBTS3030WC-11.00	GC3030S4CW	STD	2.500"	SPRING BRAKE	_fits TRAILER- VANTRAAX, INTRAAX	11.000"	
3030	PLBTS3030LSWC-11.00	GC3030LS4CW	LONG	3.000"	SPRING BRAKE	_fits TRAILER- VANTRAAX, INTRAAX	11.000"	
T16	PLBSC16WC-2.25	16SCNW1	STD	2.250"	SERVICE CHAMBER	_T16, OE#	2.250"	
T16	PLBSC16LSWC-2.25	SC16LCW	LONG	2.500"	SERVICE CHAMBER	_T16, OE#	2.250"	
T20	PLBSC20LSWC-2.25	SC20LCW	STD	2.500"	SERVICE CHAMBER	_T20, OE# 127200010	2.250"	
T24	PLBSC24WC-2.25	K058691	STD	2.500"	SERVICE CHAMBER	_T24, OE#	2.250"	
T24	PLBSC24LSWC-2.25	SC24LCW	LONG	3.000"	SERVICE CHAMBER	_T24, OE#	2.250"	
T30	PLBSC30WC-2.25	SC30CW	STD	2.500"	SERVICE CHAMBER	_T30, OE#	2.250"	
T30	PLBSC30LSWC-2.25	SC30LCW	LONG	3.000"	SERVICE CHAMBER	_T30, OE#	2.250"	
T36	PLBSC36WC-2.25	36SCLW3	LONG	3.000"	SERVICE CHAMBER	_T36, OE#	2.250"	

